

ITEM NO.	QTY	PART NUMBER	DESCRIPTION
1	1	MS-DC-1.0-01-00	BODY
2	1	MS-DC-1.0-02-00	DOOR
3	4	MS-DC-0.5-08-00	LEG
4	2	-----	7" HINGE C/W GREASE NIPPLE
5	1	MS-10-01	OPTIONAL CABINET TOP
6	2	MS-DC-1.0-04-00	ADJUSTABLE SHELF

CUSTOMER APPROVAL ENDORSEMENT

APPROVED AS SHOWN

APPROVED WITH CHANGES SHOWN

BY: _____ DATE: _____

TITLE: _____

COMPANY: _____

COMMENTS: _____

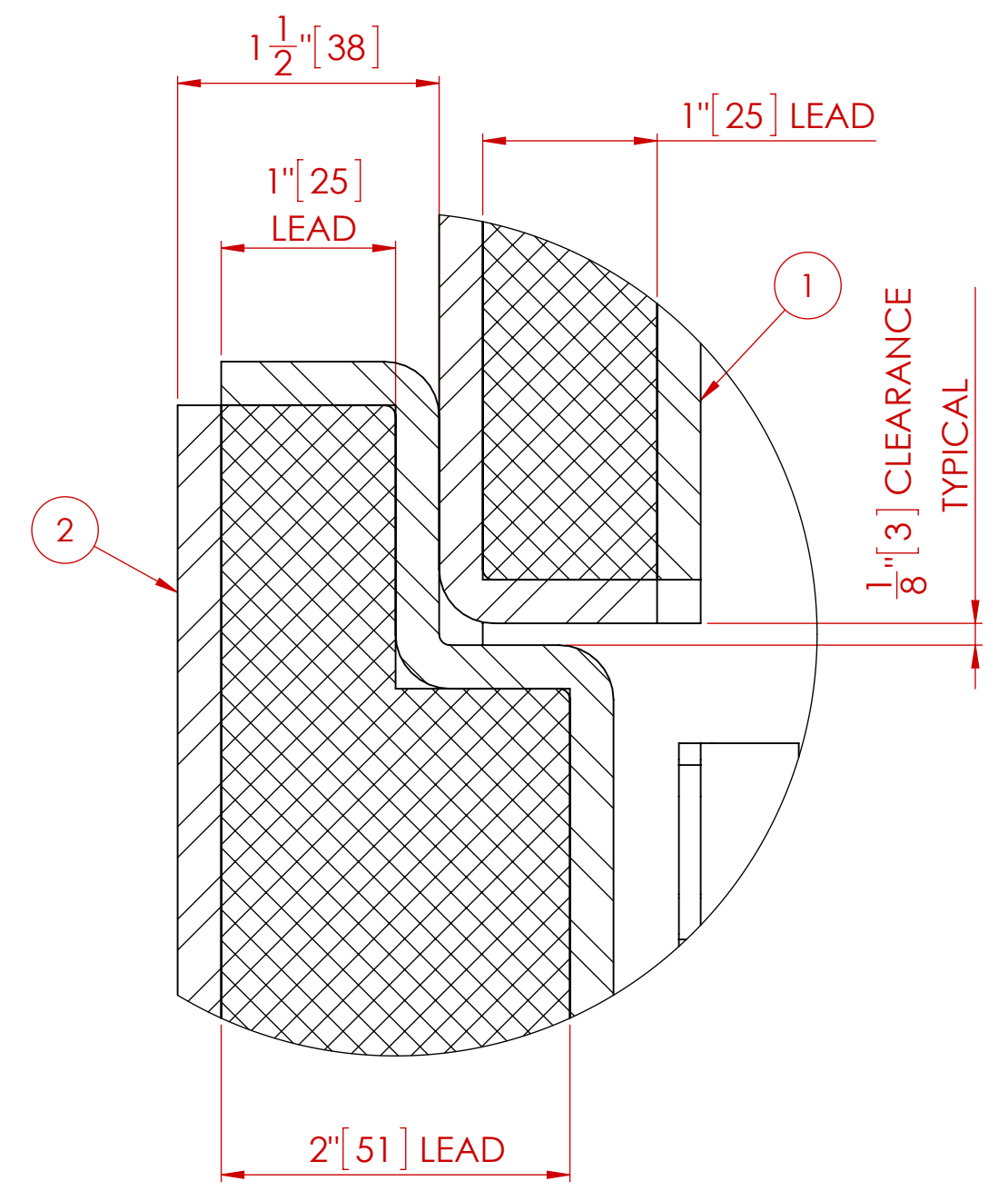
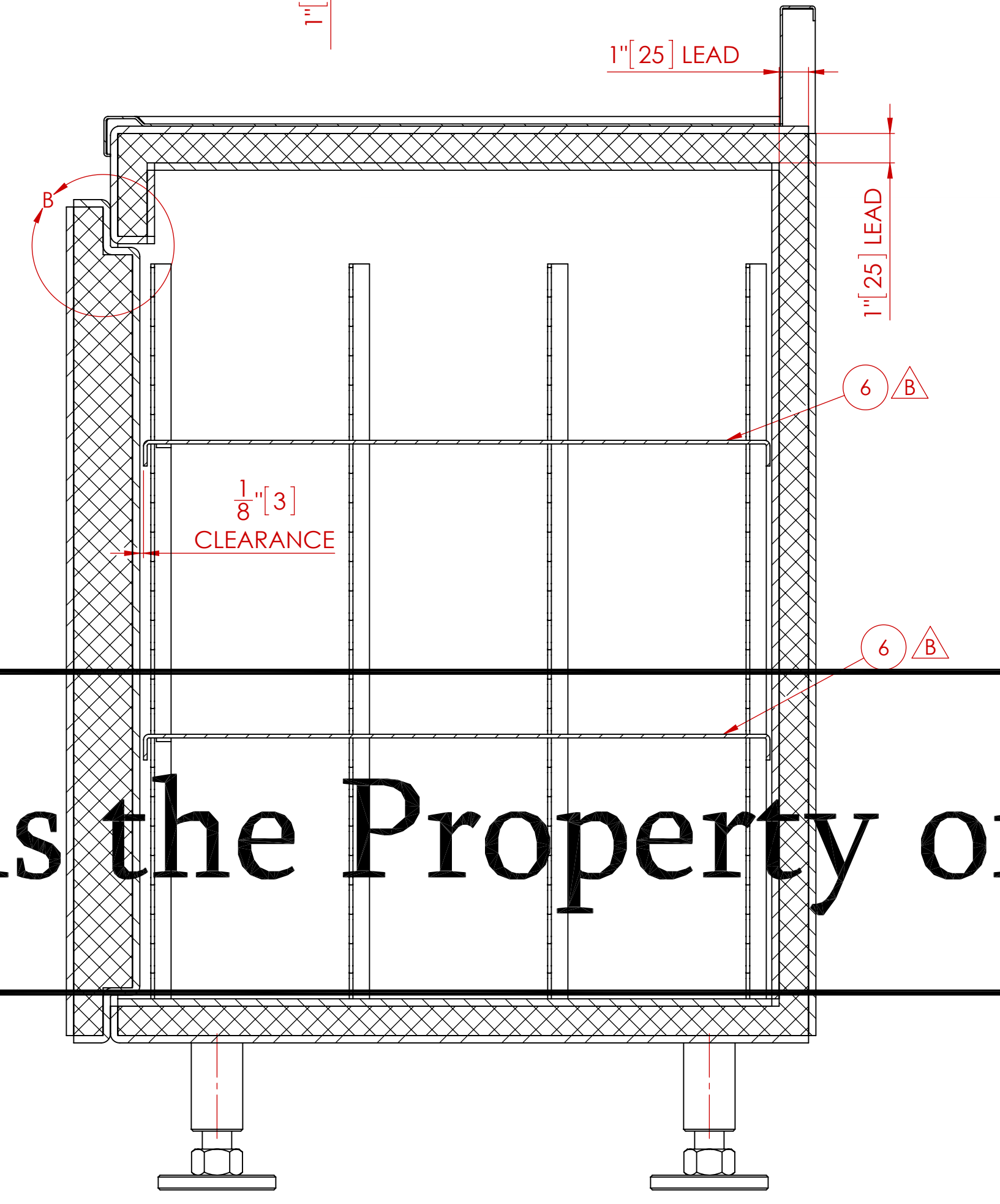
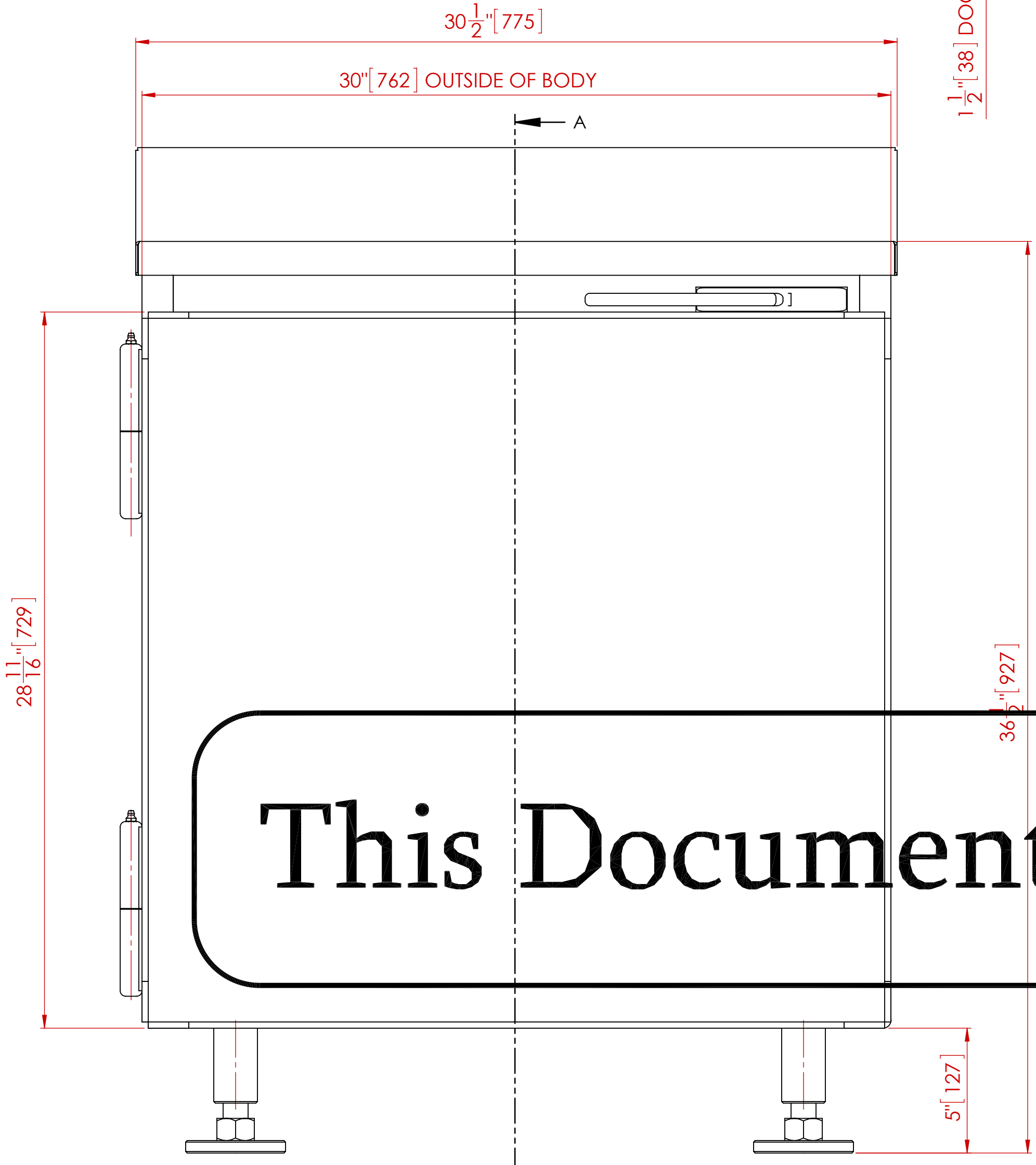
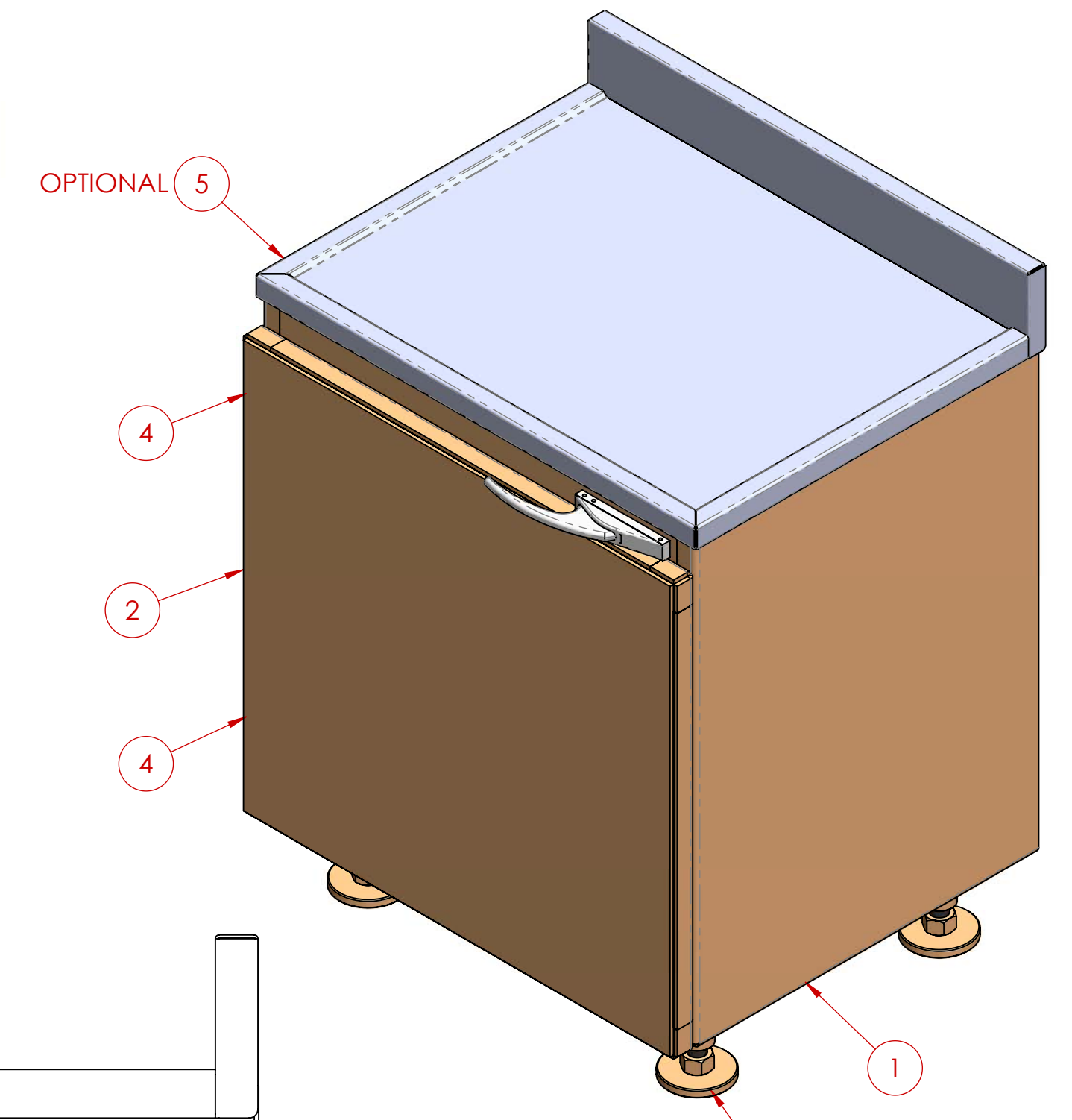
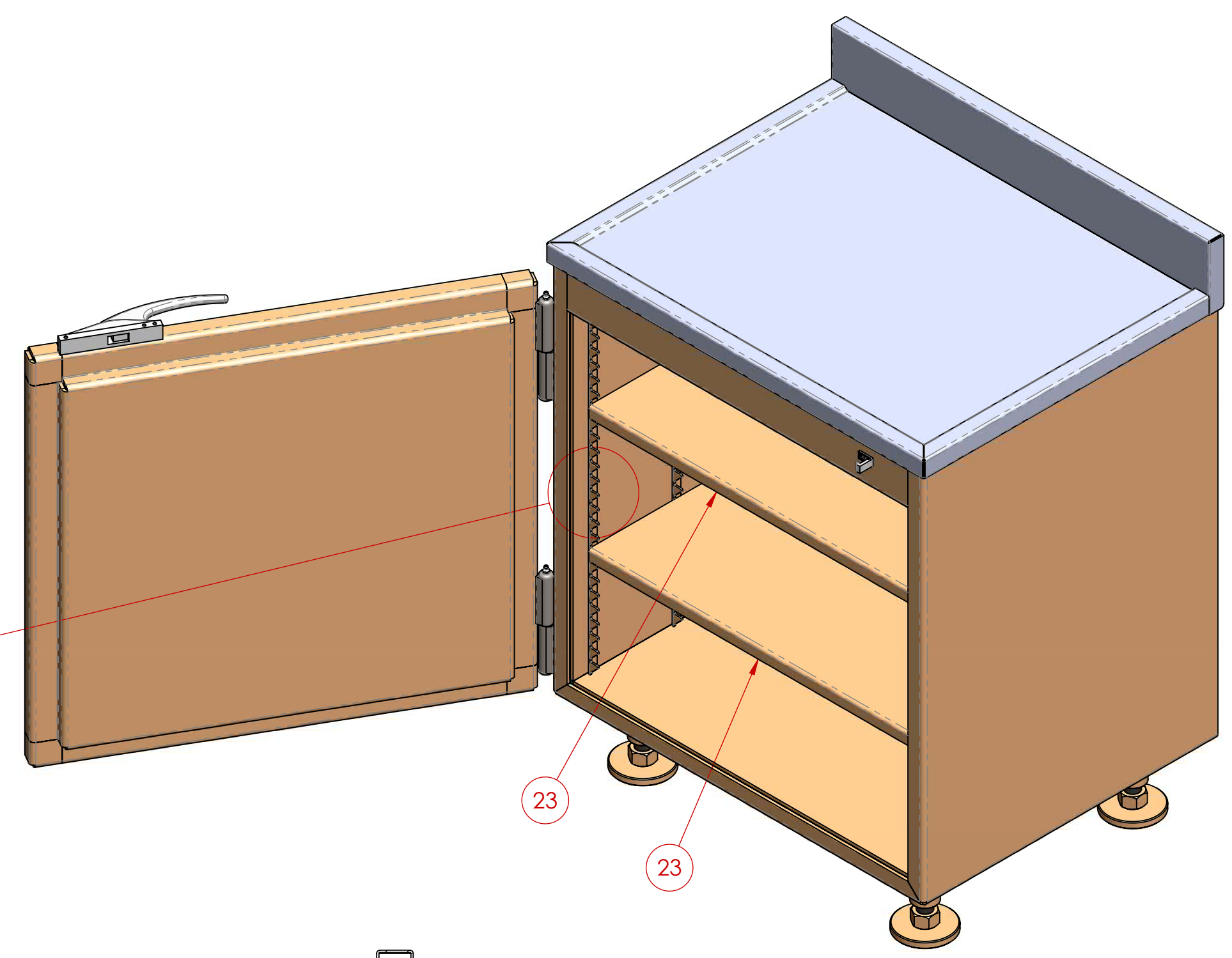
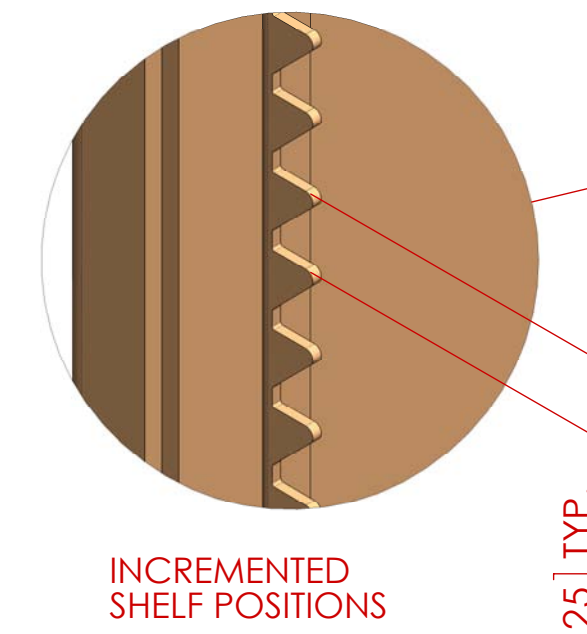
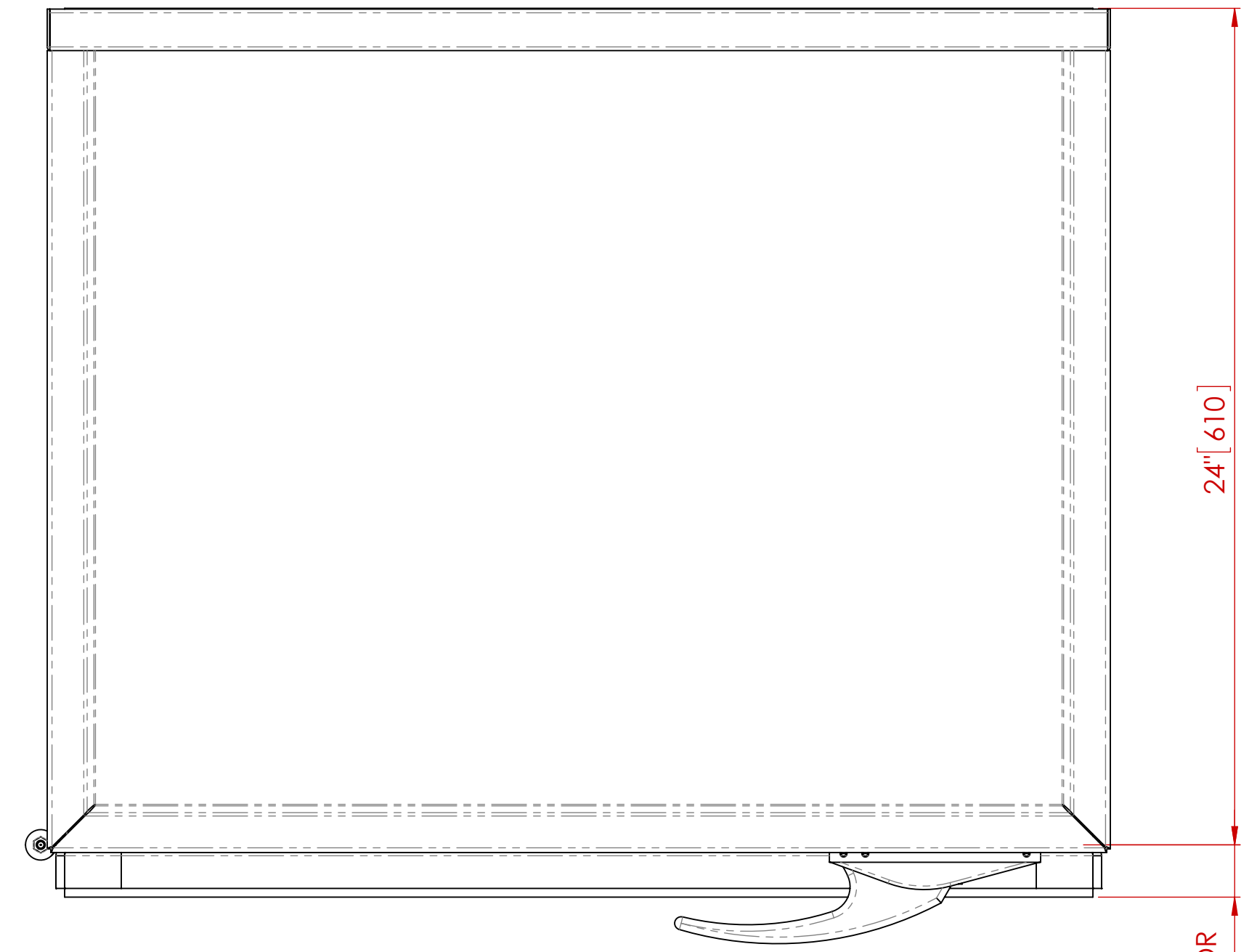

This Document is the Property of MarShield

NOTES:

1. ALL UNITS ARE INCHES [mm] UNLESS OTHERWISE SPECIFIED

2. ITEM 5 (CABINET TOP) IS OPTIONAL

TOTAL LEAD WEIGHT	TOTAL CABINET WEIGHT (INCLUDING LEAD)
2,055 LBS. (934 kg)	2,830 LBS. (1,286 kg)

REV.	DESCRIPTION	DATE	APPROVED
A	ADDED WEIGHTS TABLE	2/27/2013	M.S.D.
B	ADDED ITEM 6, SHELVES WERE FIXED	1/31/2014	M.S.D.

UNLESS OTHERWISE SPECIFIED

DO NOT SCALE DRAWING DIMENSIONS SHOWN PREFERENCES ARE FOR REFERENCE ONLY (XX) DIMENSIONS ARE IN INCHES [mm] TOLERANCES APPLY AS SHOWN BELOW X = ± 0.005 XX = ± 0.010 XXX = ± 0.020 ANGLES ± 0.016

ALL MACHINED SURFACES TO BE $\sqrt{10}$

ALL WELD SPECIFICATIONS PER WELD SHOP

PROPRIETARY NO PART OF THIS DOCUMENT MAY BE REPRODUCED, STORED IN A RETRIEVAL SYSTEM, OR TRANSMITTED IN ANY FORM, WITHOUT THE WRITTEN PERMISSION OF MarShield - MGR Metall Company DIVISION OF Marshfield Metal Industries Ltd.

SolidWorks MAINTAINED DATA CHANGES SHALL BE INCORPORATED ELECTRONICALLY BY THE DESIGN ACTIVITY

MODEL NUMBER: _____

TITLE: DECAY CABINET ASSEMBLY

CUSTOMER/DEALER: _____

DRAWN BY: M.S.D. DATE: 2/17/2013

CHECKED BY: _____ DATE: _____

APPROVED: _____ DATE: _____

SCALE: 1:4 WEIGHT: 1 SHEET 1 OF 1

MarShield Custom Radiation Protection, Shielding and Storage

MS-DC-1.0-30.5-24-36.5