

CUSTOMER APPROVAL ENDORSEMENT

APPROVED AS SHOWN
 APPROVED WITH CHANGES SHOWN

BY: _____ DATE: _____
 TITLE: _____
 COMPANY: _____
 COMMENTS: _____

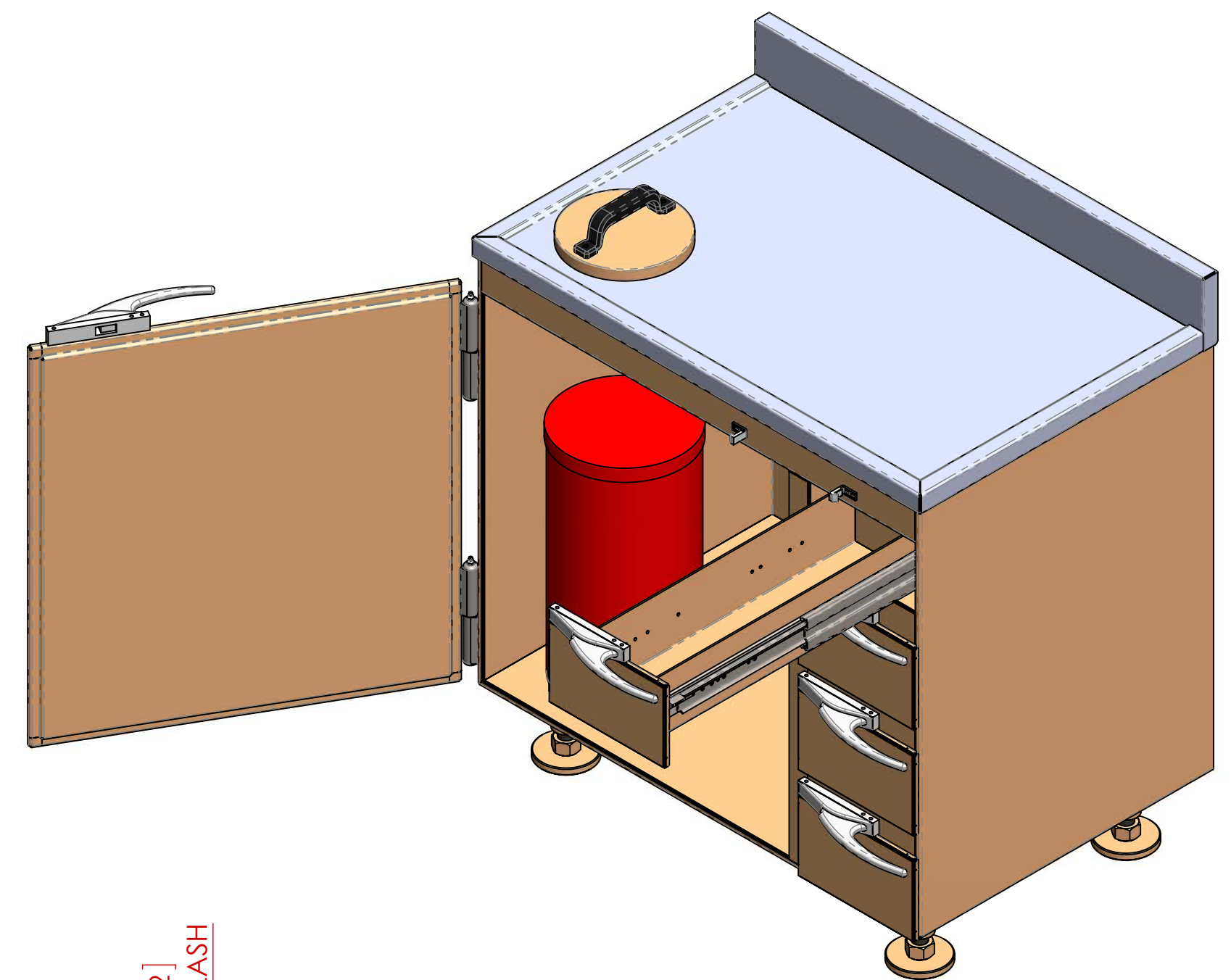

ITEM NO.	QTY	PART NUMBER	DESCRIPTION
1	1	MS-WSC-0.25-01-00	BODY
2	1	MS-DSC-0.25-02-00	DOOR
3	4	MS-DC-0.5-08-00	LEG
4	2	-----	7" HINGE C/W GREASE NIPPLE
5	4	MS-DSC-0.25-03-00	DRAWER
6	1	-----	OPTIONAL SHARPS HOLE C/W LEAD FILLED COVER
7	1	MS-10-04	OPTIONAL CABINET TOP

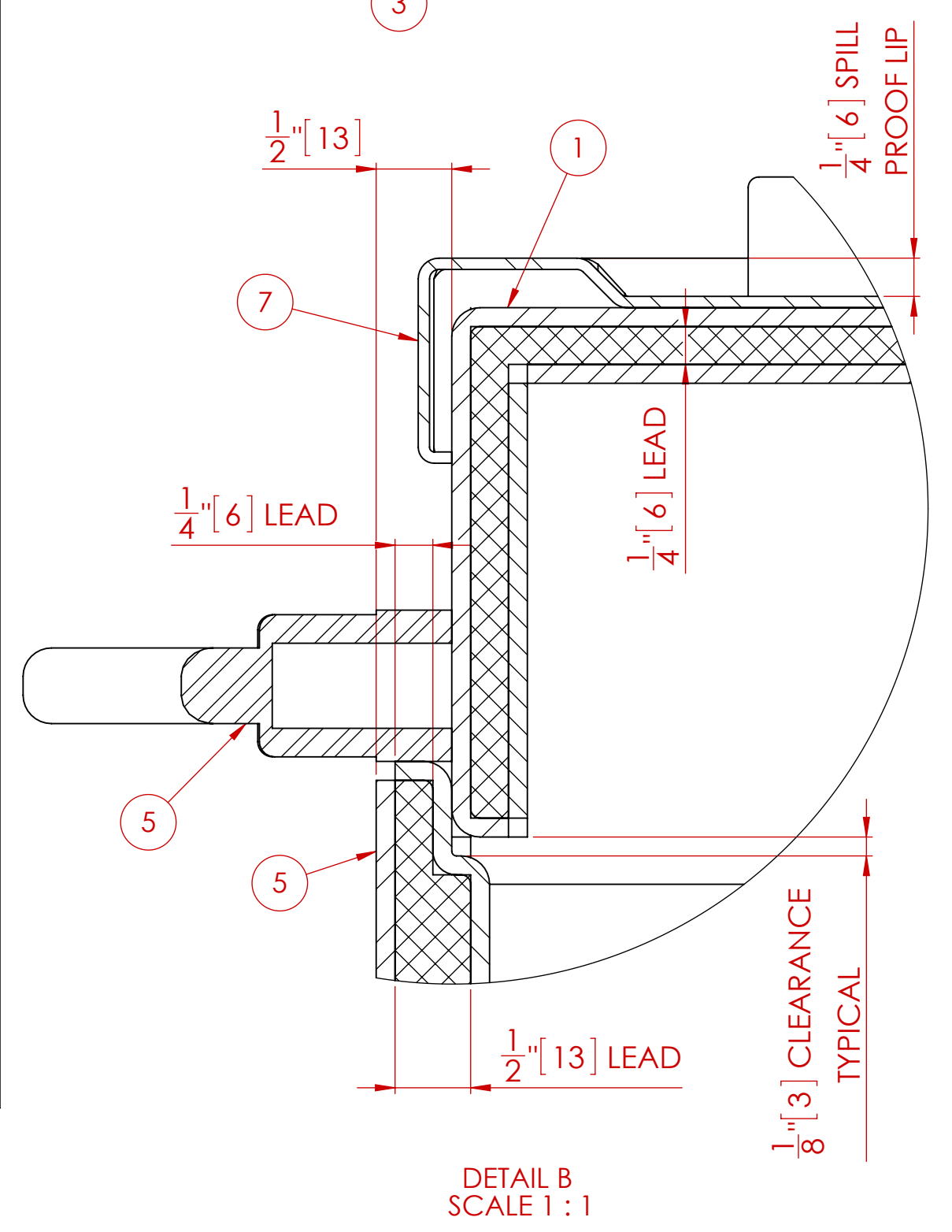
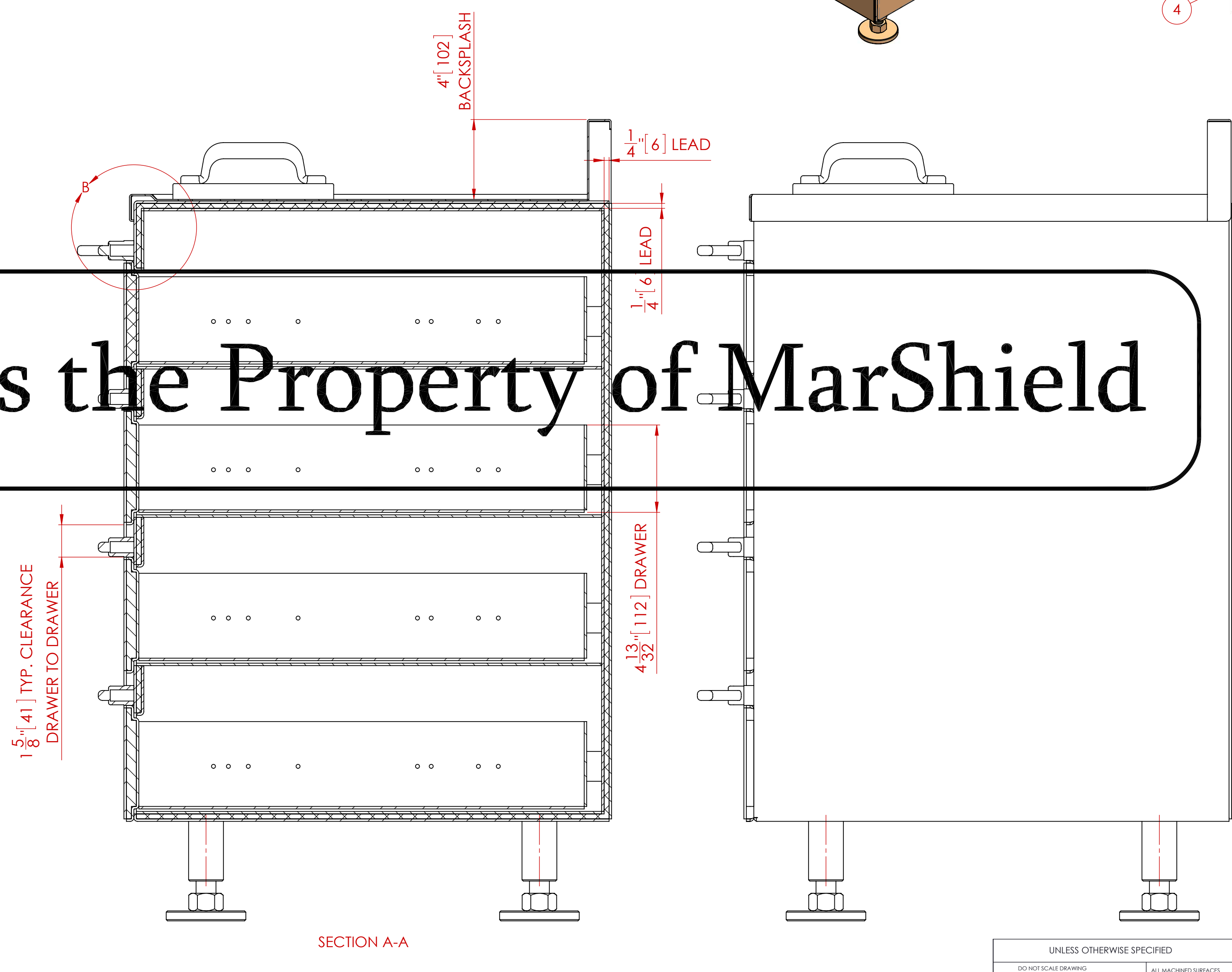
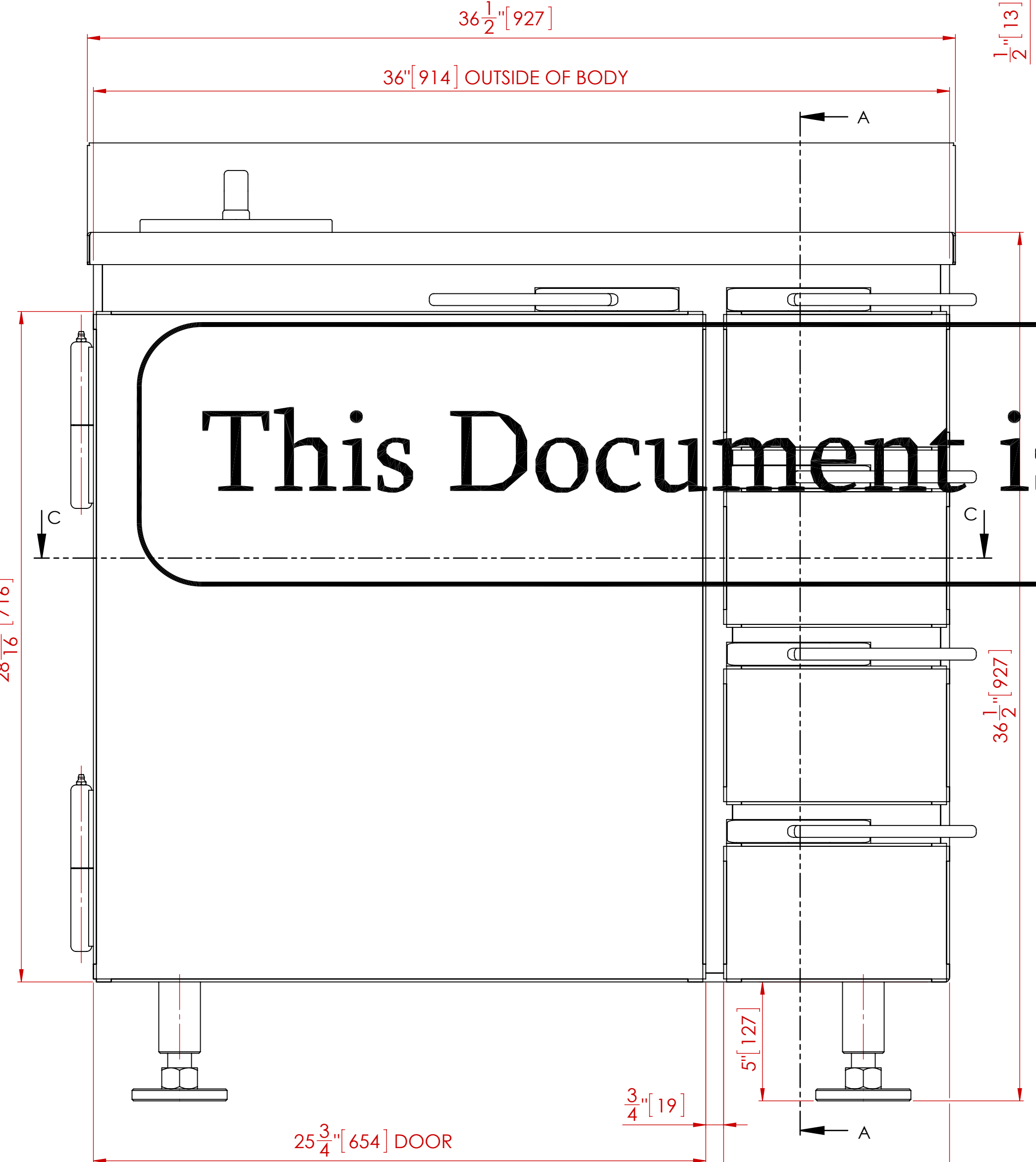
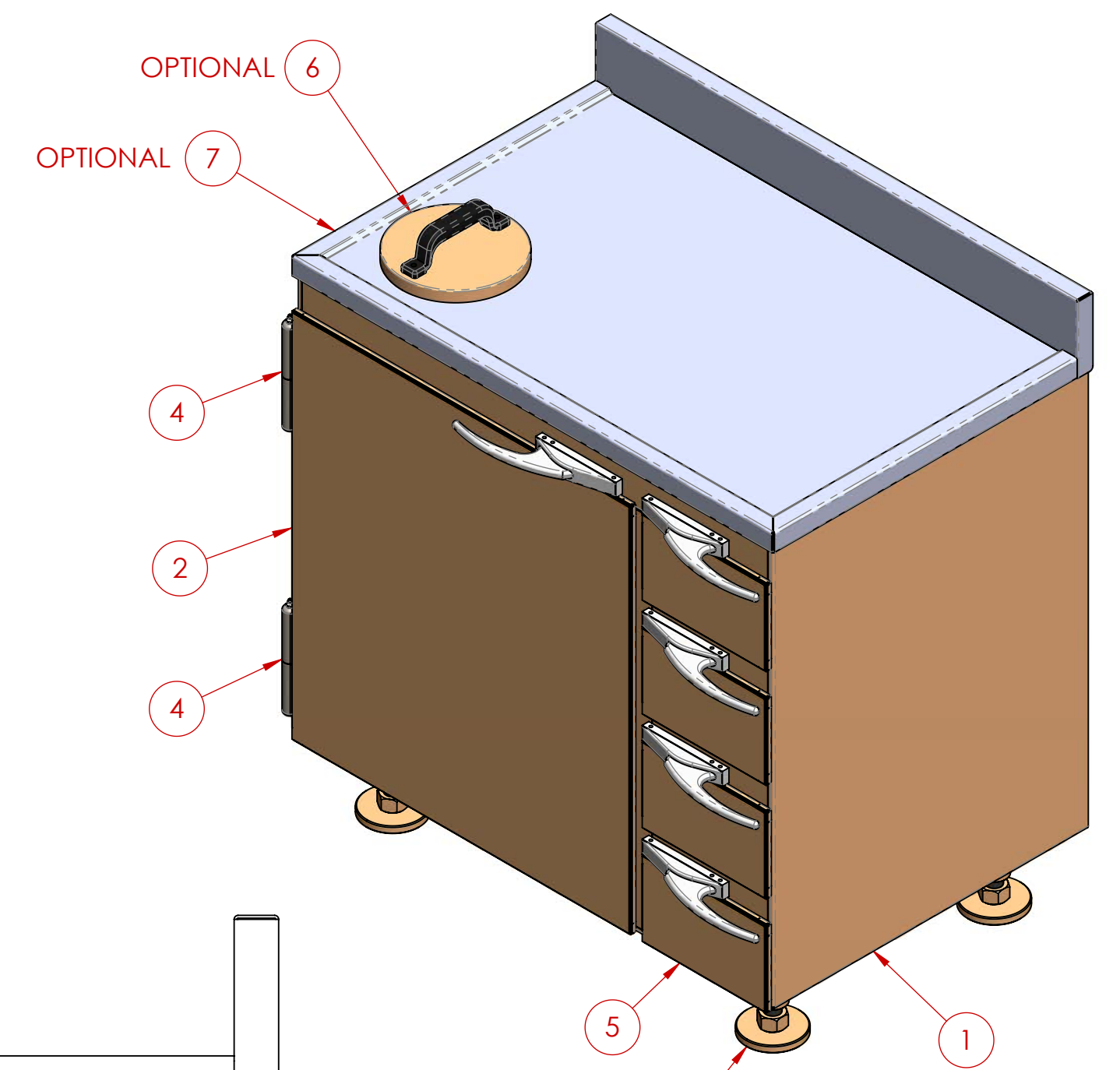

This Document is the Property of MarShield

- NOTES:**
1. ALL UNITS ARE INCHES [mm] UNLESS OTHERWISE SPECIFIED
 2. ITEM 6 (CABINET TOP) IS OPTIONAL
 3. ITEM 7 (SHARPS HOLE & COVER) IS OPTIONAL

TOTAL LEAD WEIGHT	TOTAL CABINET WEIGHT (INCLUDING LEAD)
630 LBS. (286 kg)	1,275 LBS. (580 kg)

REV.	DESCRIPTION	DATE	APPROVED
A	ADDED WEIGHTS TABLE	2/27/2013	M.S.D.

UNLESS OTHERWISE SPECIFIED

DO NOT SCALE DRAWING DIMENSIONS SHOWN PREFERABLE ARE FOR REFERENCE ONLY (XXI) DIMENSIONS ARE IN INCHES [mm] TOLERANCES APPLY AS SHOWN BELOW
 X = ± 0.005
 XX = ± 0.010
 XXX = ± 0.020
 ANGLES = ± 0.016

ALL MACHINED SURFACES TO BE ALL WELD SPECIFICATIONS PER WELD SHOP

PROPRIETARY NO PART OF THIS DOCUMENT MAY BE REPRODUCED, STORED IN A RETRIEVAL SYSTEM, OR TRANSMITTED IN ANY FORM, WITHOUT THE WRITTEN PERMISSION OF MarShield - MGR Metal Company DIVISION OF Marshall Metal Industries Ltd.

SolidWorks MAINTAINED DATA CHANGES SHALL BE INCORPORATED ELECTRONICALLY BY THE DESIGN ACTIVITY

MODEL NUMBER: _____

TITLE: **WASTE & STORAGE CABINET ASSEMBLY**

CUSTOMER/DEALER: _____

DESIGNED BY: M.S.D. DATE: 2/14/2013

DRAWN BY: M.S.D. DATE: 2/14/2013

CHECKED BY: _____ DATE: _____

APPROVED BY: _____ DATE: _____

SCALE: 1:4 HEIGHT

MS-WSC-0.25-36.5-24-36.5

SHEET 1 OF 1