

Model Shown with Doors and Access Panels removed

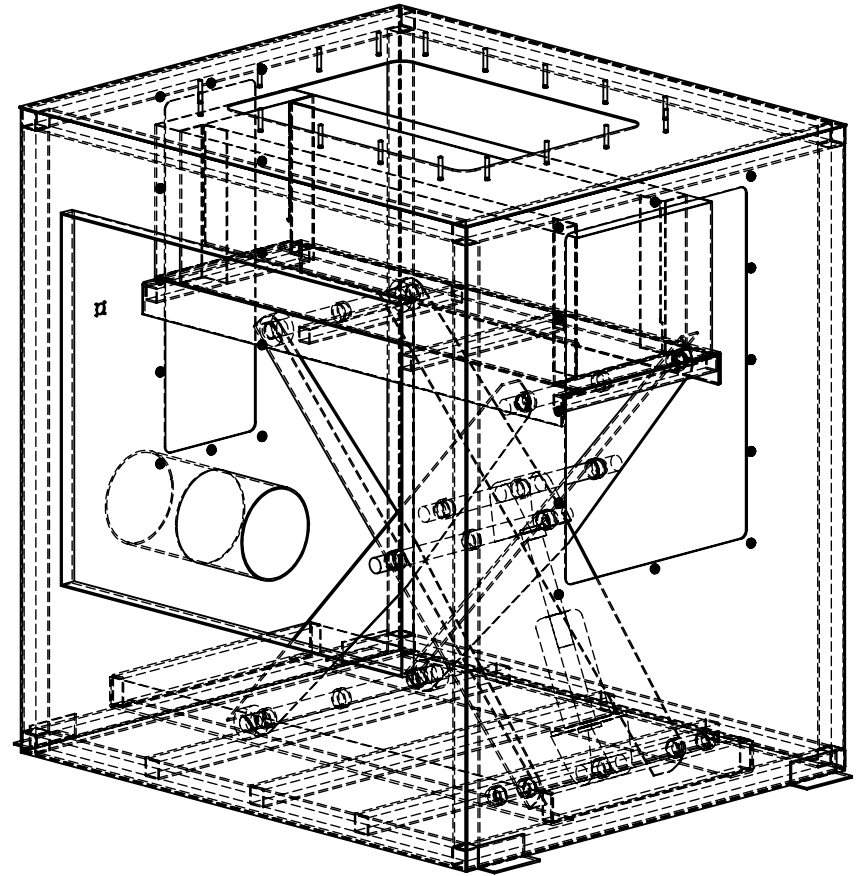

<p>PROPRIETARY AND CONFIDENTIAL</p> <p>THE INFORMATION CONTAINED IN THIS DRAWING IS THE SOLE PROPERTY OF MARSHIELD. ANY REPRODUCTION IN PART OR AS A WHOLE WITHOUT THE WRITTEN PERMISSION OF MARSHIELD IS PROHIBITED.</p>	SIZE	DWG. NO.	REV
	A	Mars Detector Box 7410 Lower Chamber	
SCALE: 1:16	WEIGHT:	SHEET 1 OF 5	

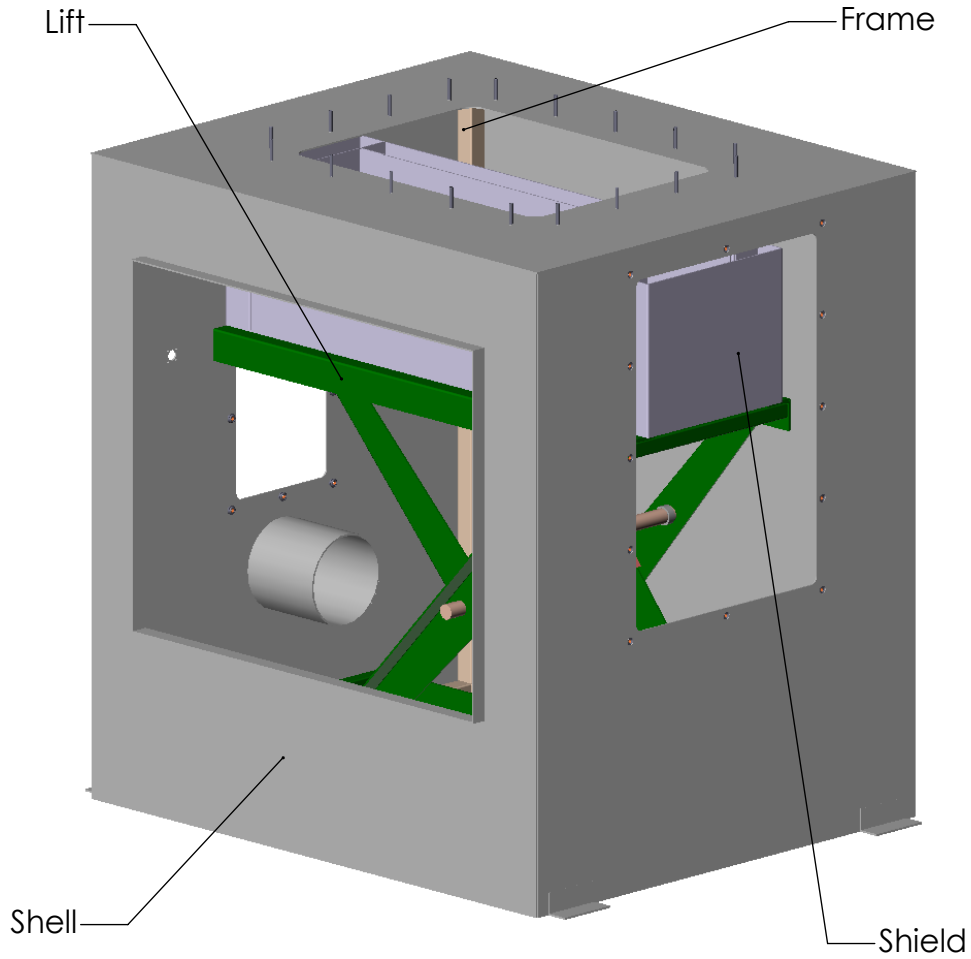
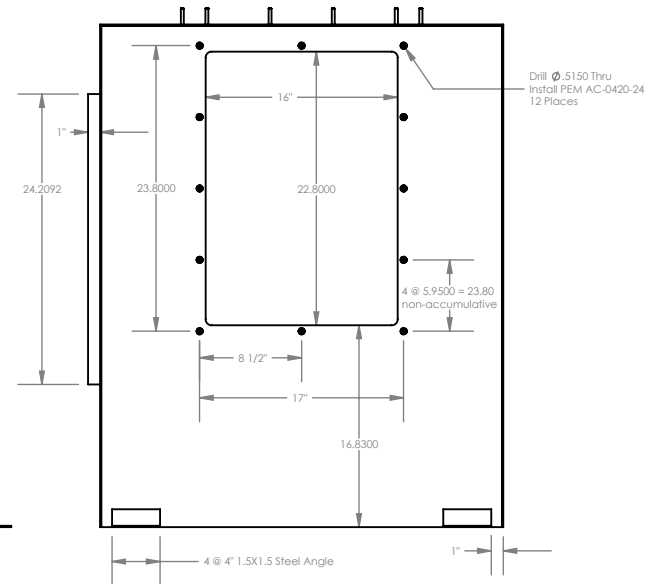
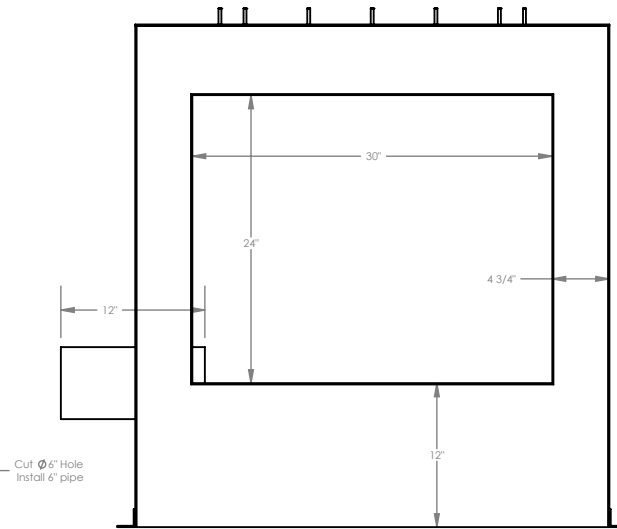
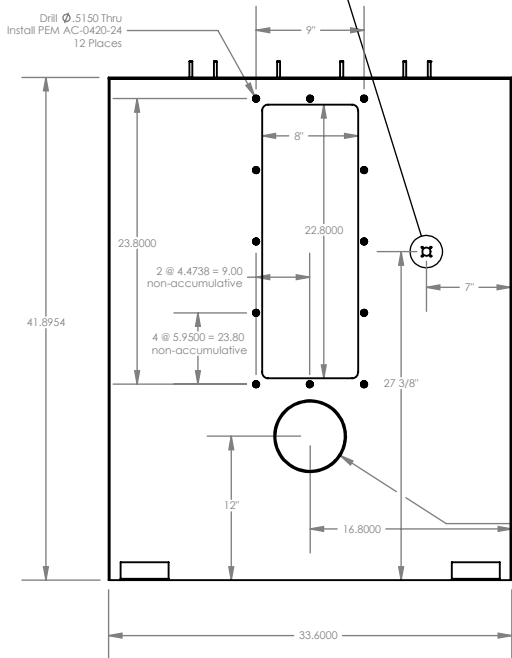
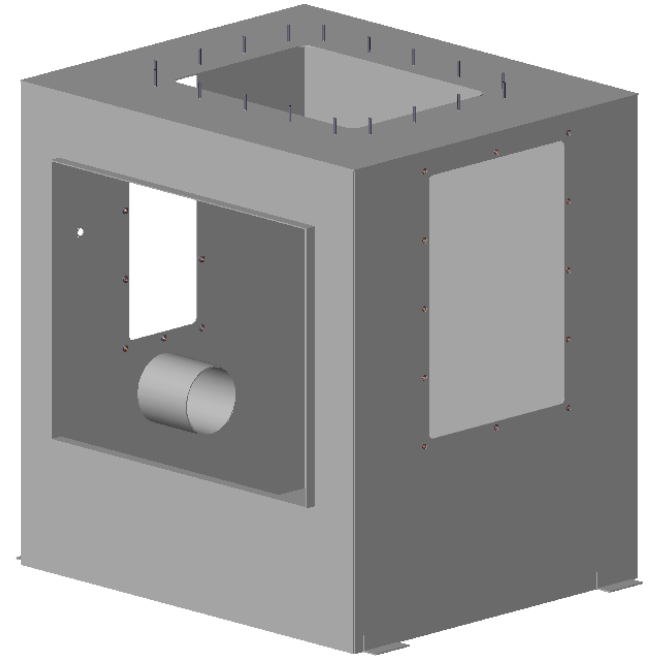
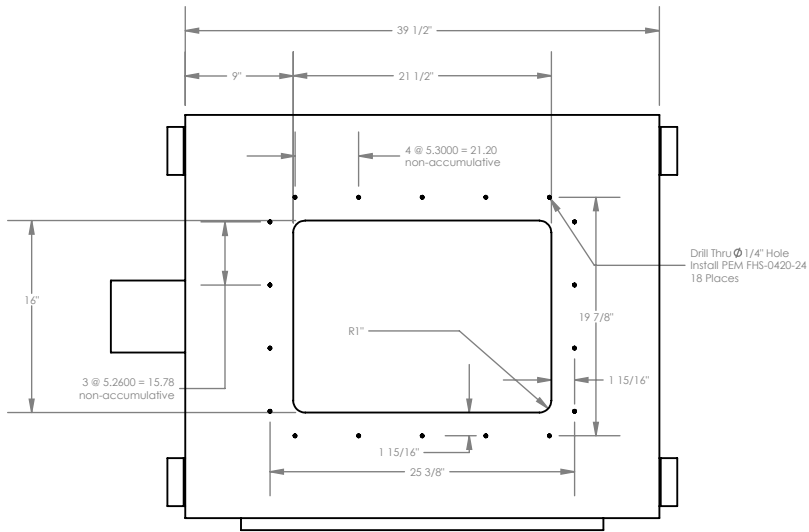
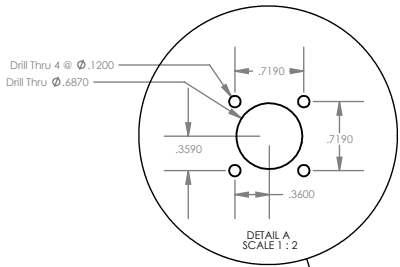

PROPRIETARY AND CONFIDENTIAL THE INFORMATION CONTAINED IN THIS DRAWING IS THE SOLE PROPERTY OF MARSHIELD. ANY REPRODUCTION IN PART OR AS A WHOLE WITHOUT THE WRITTEN PERMISSION OF MARSHIELD IS PROHIBITED.	SIZE	DWG. NO.	REV
	A	Mars Detector Box 7410 Lower Chamber	
	SCALE: 1:16	WEIGHT:	SHEET 2 OF 5

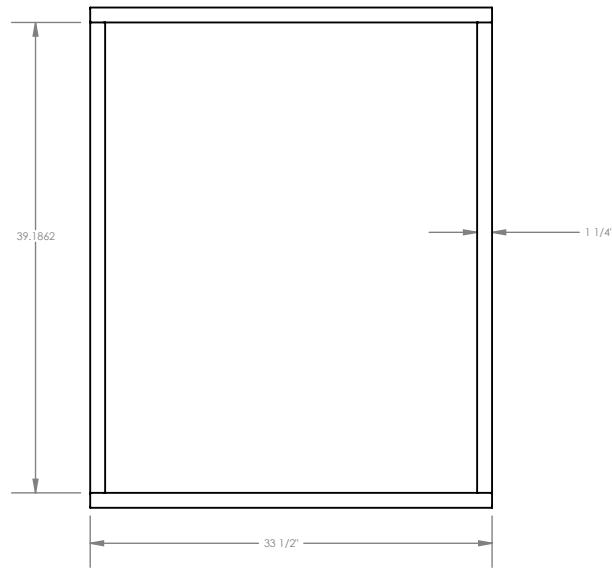
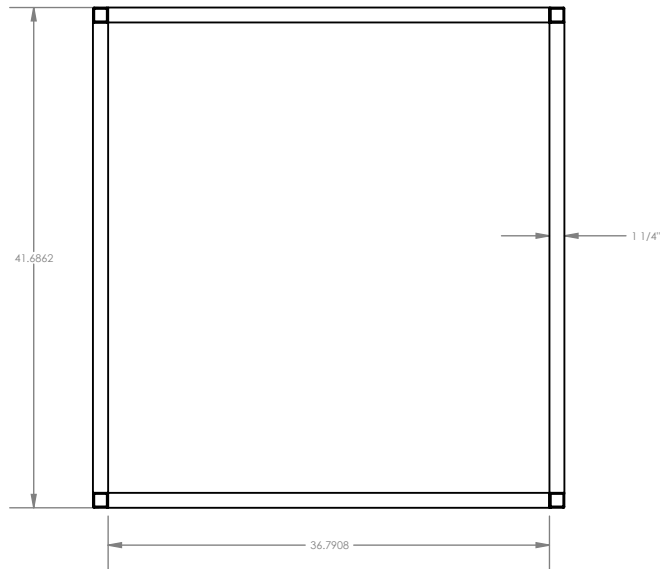
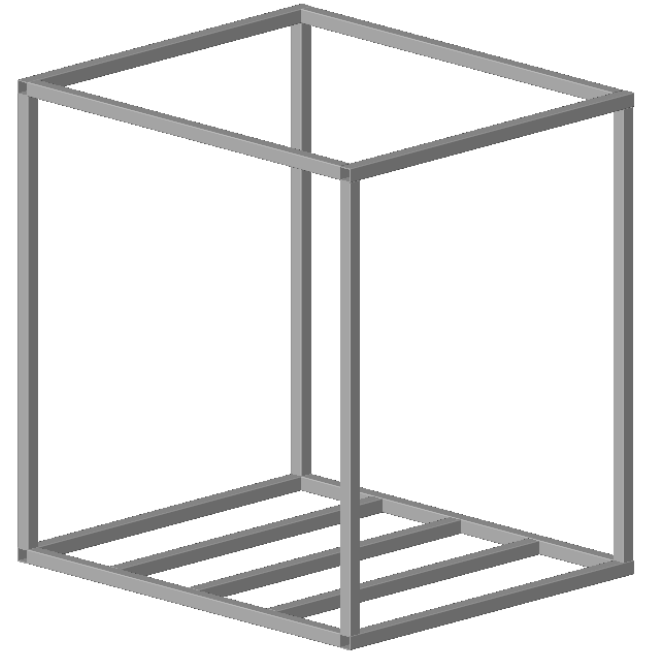
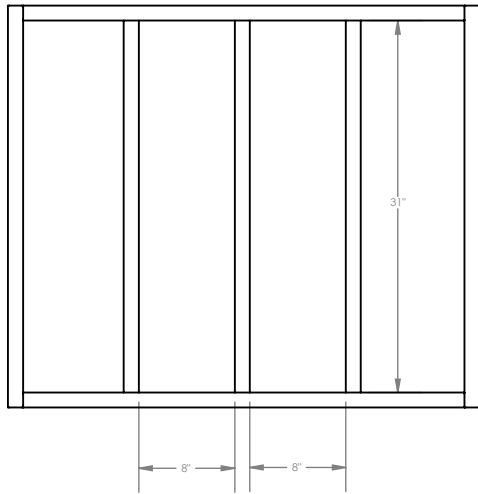

<p>PROPRIETARY AND CONFIDENTIAL</p> <p>THE INFORMATION CONTAINED IN THIS DRAWING IS THE SOLE PROPERTY OF MARSHIELD. ANY REPRODUCTION IN PART OR AS A WHOLE WITHOUT THE WRITTEN PERMISSION OF MARSHIELD IS PROHIBITED.</p>	<p>SIZE</p> <p>A</p>	<p>DWG. NO.</p> <p>Mars Detector Box 7410 Lower Chamber</p>	<p>REV</p>
	<p>SCALE: 1:16</p>	<p>WEIGHT:</p>	<p>SHEET 3 OF 5</p>

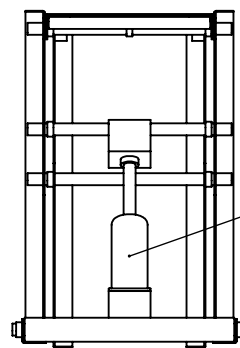
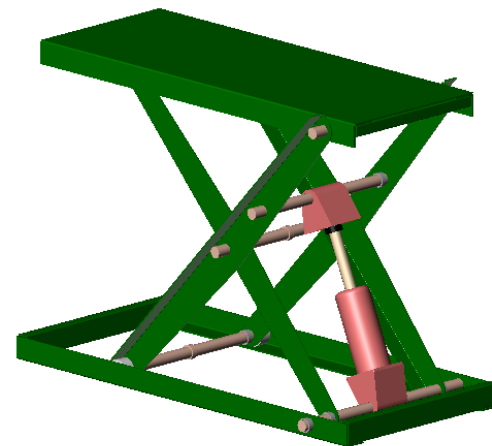
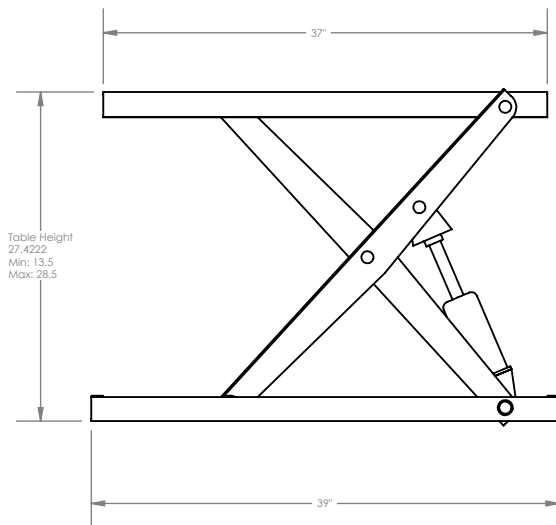
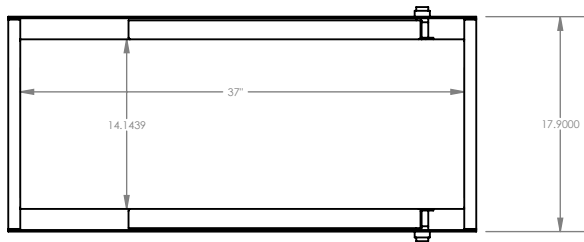

2 Ton Hydraulic Bottle Jack
Hand Operated

PROPRIETARY AND CONFIDENTIAL

THE INFORMATION CONTAINED IN THIS DRAWING IS THE SOLE PROPERTY OF MARSHIELD. ANY REPRODUCTION IN PART OR AS A WHOLE WITHOUT THE WRITTEN PERMISSION OF MARSHIELD IS PROHIBITED.

SIZE	DWG. NO.	REV
A	Mars Detector Box 7410 Lower Chamber	
SCALE: 1:16	WEIGHT:	SHEET 4 OF 5

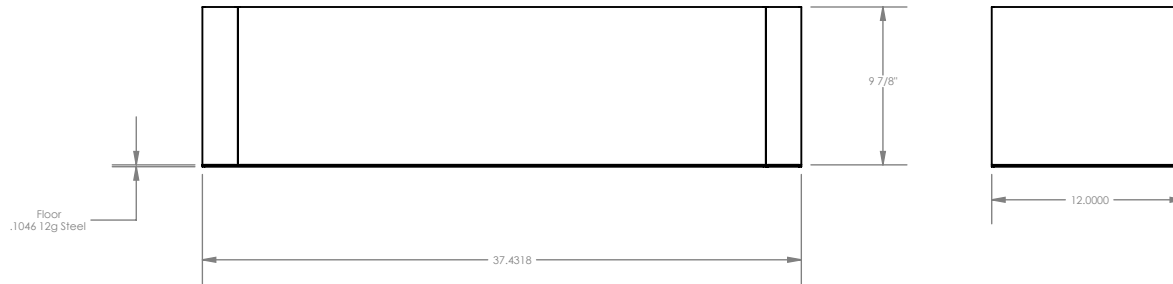
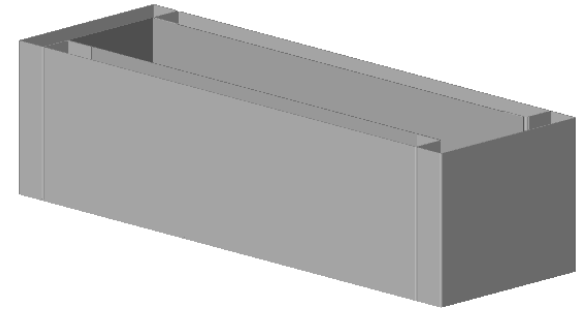
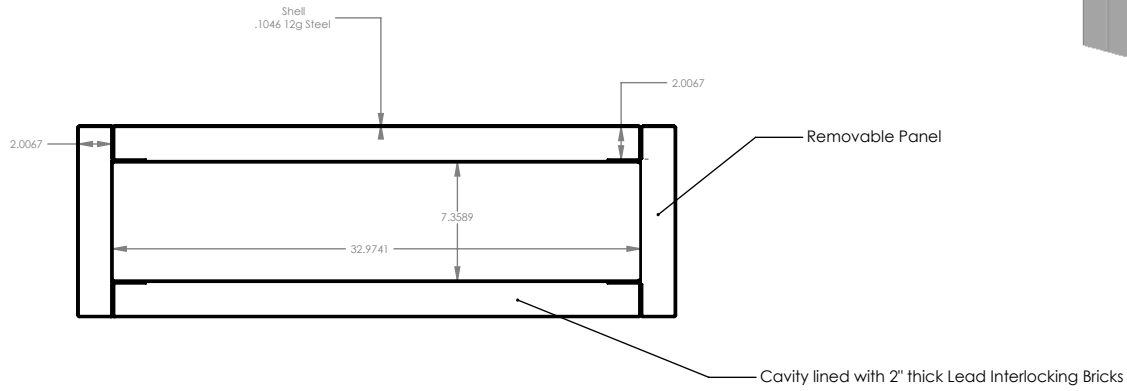

<p>PROPRIETARY AND CONFIDENTIAL</p> <p>THE INFORMATION CONTAINED IN THIS DRAWING IS THE SOLE PROPERTY OF MARSHIELD. ANY REPRODUCTION IN PART OR AS A WHOLE WITHOUT THE WRITTEN PERMISSION OF MARSHIELD IS PROHIBITED.</p>	<p>SIZE</p> <p>A</p>	<p>DWG. NO.</p> <p>Mars Detector Box 7410 Lower Chamber</p>	<p>REV</p>
	<p>SCALE: 1:12</p>	<p>WEIGHT:</p>	<p>SHEET 5 OF 5</p>